



November 7, 2024

### W Frontage Road Reconstruction

**When:** Complete reconstruction of the W Frontage Road occurs between November 2024 to Fall-2026

**Coordination:** The construction project team has coordinated with the Troy Township Fire Protection District over the past year. The Fire Protection District drove its fire trucks at the start of the construction and can safely navigate through the work zone.

**What work is being done?**

As part of the I-80 Reconstruction, this three-year project between River Road and Houbolt Road rebuilds I-80 and the following bridges: DuPage River, new I-55 Ramps, W Frontage Road, Rock Run Creek, and I-55.

**Why is this work being done on the SW Frontage Road?**

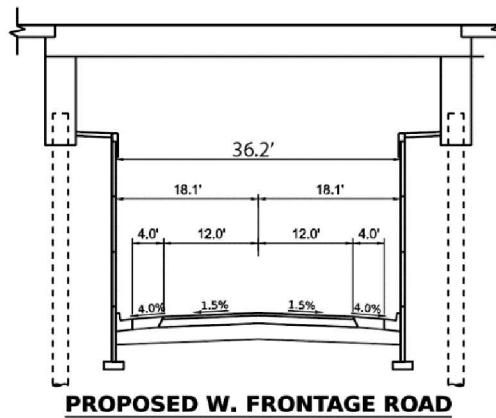
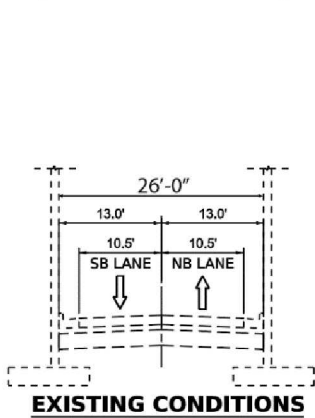

**Improved Traffic Flow/Visibility:** The wider bridge will accommodate a 10-foot wider road than the existing conditions. Lane widths will increase to 12 feet with the addition of 4-foot shoulders, improving the overall traffic flow and allowing better visibility and maneuverability for drivers.

**Underpass Lighting:** Added for improved nighttime visibility.

**Improved Drainage:** New storm sewer will prevent flooding on W Frontage Road.

**Current Traffic Impact:**

- Start Date: November 1, 2024
- End Date: December 15, 2024
  - Traffic will be reduced to one lane in each direction, controlled by a temporary traffic signal.
  - Lane width is reduced to 10' wide (signed 8'-6") with concrete barriers protecting the work zones.
  - Traffic should expect longer wait times at the traffic signals due to the distance between them.
    - Wait time can be up to 3 minutes for the signal to change and allow traffic to pass through the work zone.
    - Please wait for the signals to change.
  - Motorists should use caution when passing through the work zone due to the narrow lane.

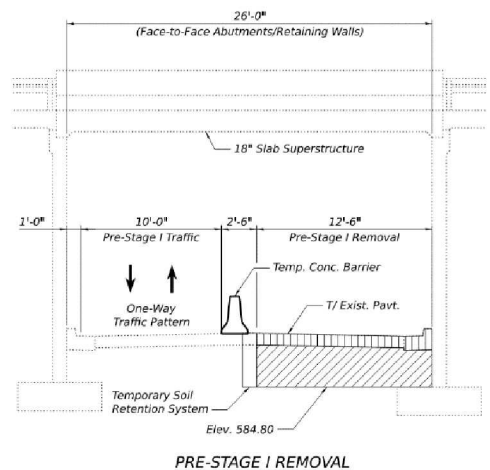



**I·80WILL**  
ADVANCE. REBUILD. TRANSFORM.

# PROJECT NOTICE

**I-80 | River Road to Houbolt Road  
Reconstruction**

**Current Work:** Remove the existing pavement and construct temporary pavement for NB and SB lanes.



**Winter 2024-2025 Traffic Pattern:** Once all the temporary pavement is installed over the next few weeks, traffic will be placed back in two (2) lanes before winter, with an increased lane width of 11 feet from the existing 10.5-foot lanes.

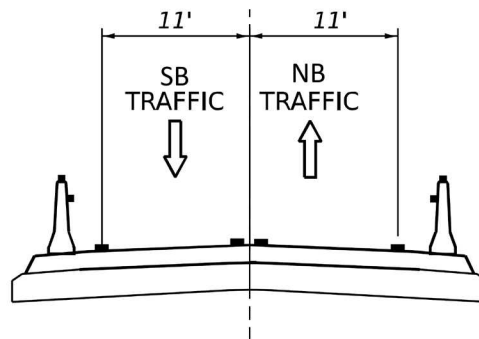

*Will be back constructing the next stage in Spring 2025. Additional information will be provided.*

**I-80 Reconstruction:** The overall I-80 project will redesign and rebuild 16 miles from Ridge Road, in Minooka, to U.S. 30, in Joliet and New Lenox while adding or extending auxiliary lanes to improve safety and reduce congestion. Interchanges will be rebuilt or improved at Interstate 55, Illinois 7, Center Street, Chicago Street, Richards Street, and Briggs Street, with a new flyover ramp linking southbound I-55 to eastbound I-80 to improve traffic flow and safety. More than 30 bridges will be rehabilitated or replaced, including those over the Des Plaines River. The projected \$1.3 billion project is anticipated to be substantially complete by the end of 2028, with landscaping, bridge demolition, and miscellaneous work extending into 2029.

**We Understand the Inconvenience:** We recognize that this construction may cause disruptions to your daily routines. Your patience and understanding are greatly appreciated as we work to improve our infrastructure for a safer and more efficient roadway.

---

For any questions or concerns regarding the I80 project, please visit our website  
<https://www.i80will.org/> or leave a message at the Project Hotline at 1-844-480-4255